**Staging a Scroll & a VFD Recip Compressor
APP- 035**

THEORY

The original system has a 3 ton scroll compressor with no staging. Additional refrigeration was needed for expansion and it was decided to go with a 14 ton compressor with a VFD on it. The problem is that with the VFD running at min frequency it still has 6 ton capacity. If the new VFD compressor is C1 and the old scroll is C2, the staging needs to be as follows:

C2 on first
C1 on second with C2 off
C1 on third with C2 on

C1 will run the CR-110 VSC software with a profile of VFD Comp and a PID mode of Comp Freq. The C2 compressor will run with the CR-110 conventional software with a profile of Basic Refrig and no PID mode.

The C1 VSC software allows outputs 7 & 8 to be programmed as stages for other compressors. These stage outputs have an off percentage and an on percentage. This percentage is not the percentage from the control panel but rather the PID percentage from the suction control. This is the same percentage that drives the VFD. Thus you can turn the stage on when the VFD reaches 90% and then keep it on until the VFD backs down to say 50%.

In this case, the CR-110 scroll compressor needs an input that will force the compressor into standby. Input 6 is normally the 0-20ma input from the panel when running in the input mode of ma signal. This input is only used on Card # 1: all other cards do not use this input. A change has been made so that when this input is shorted on any cards greater than # 1, it will force the card into a standby condition. If the compressor is running, it will pump down, short cycle and then go into standby. If the compressor is already in standby, it will just keep it in this condition.

For this particular case, we will use two contacts in series. One contact will be a normally open contact that will close when ever compressor C1 is running. The second contact will be a normally closed contact that will open when Stage 1 output 7 is on for C1. The result will be C2 will be held in standby anytime C1 is running, except when Stage 1 is active.

C2's LLS will be set to go on at 10% and off at 5%. C1's LLS will be set to go on at 30% and off at 20%. A normal stage up sequence would be for C2 to start, then C1 would start and C2 would shut off. When C1's VFD reached 90%, both C1 and C2 would run. To stage down C1 VFD would have to drop below 50% and then C2 would shut off. If the output drops below 20%, C1 would turn off and C2 would start.

C1 Wiring Diagram

Analog Inputs

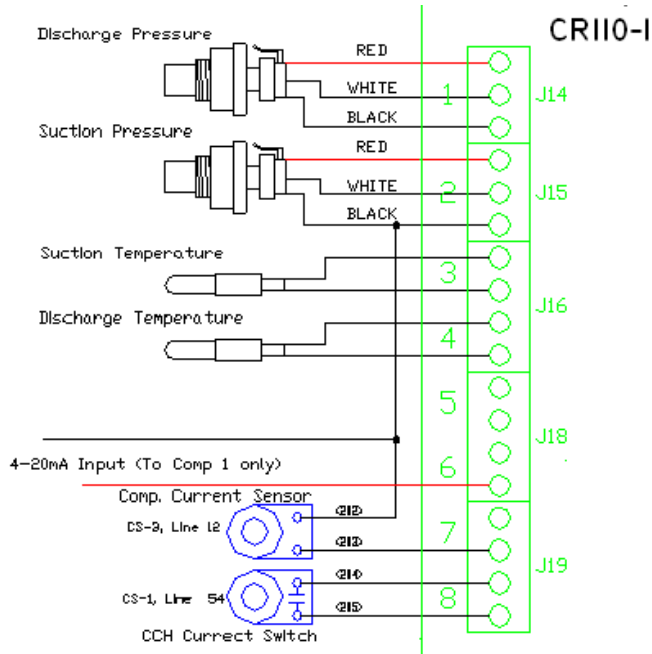

For Card 1, the analog inputs are standard.

Digital Outputs

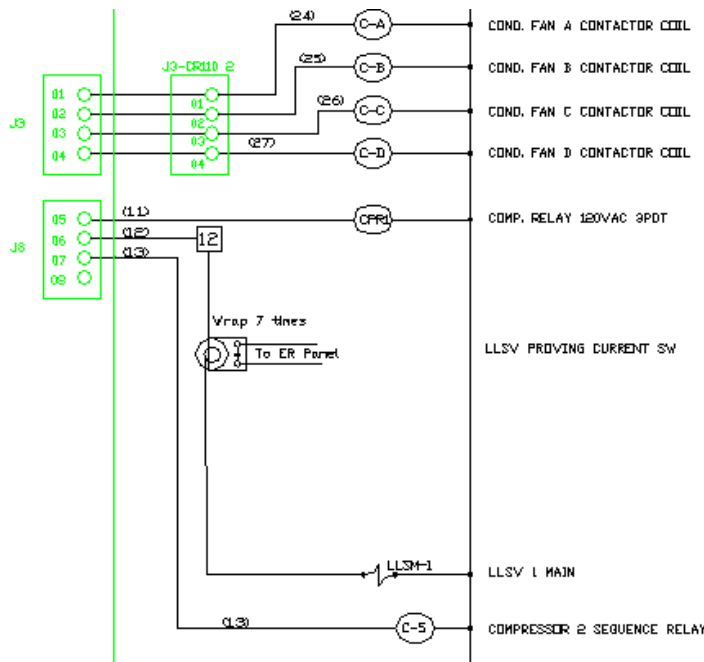

For Card 1, output 7 is used to control a sequence relay for compressor 2.

C2 Wiring Diagram

Analog Inputs

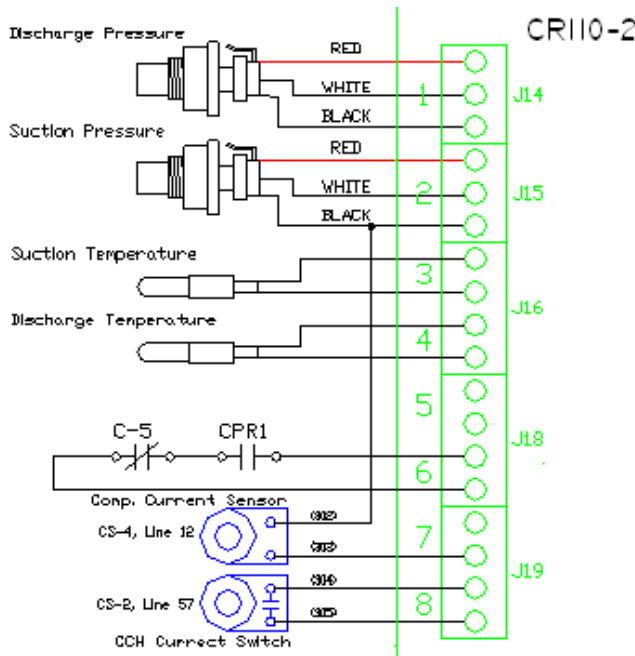

For Card 2, the only change is input 6. Two contacts, C-5 and CPR1 are connected in series across input 6. When this circuit is made it will force C2 into standby condition. CPR1 is the compressor 1 run relay. C-5 is the Stage 1 relay from card 1. CPR1 will keep C2 from running when compressor C1 is on. Once C1 VFD reaches 90%, C-5 will pickup and allow C2 to run.

Software Configuration

In this application, two different inf Xbase files are used. C1 uses the VFD Compressor and C2 uses the basic CR-110 file.

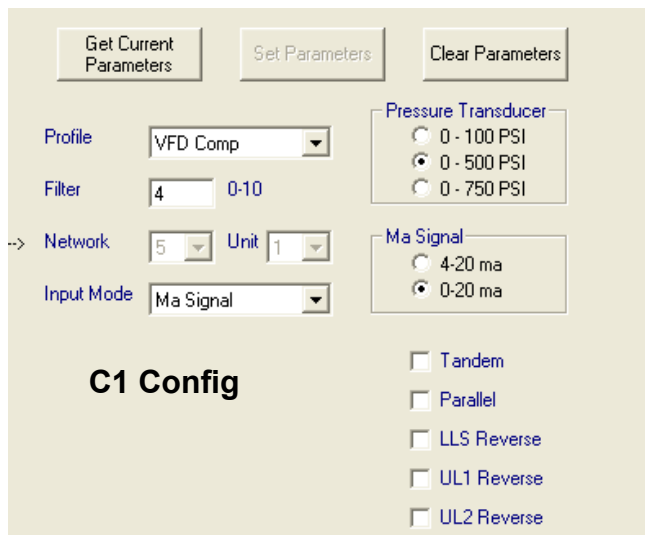

| | | | | | |
|-------------|----------------------------------|-----|-------------|----------------------------------|-----|
| Comp_off | <input type="text" value="10"/> | psi | High Dis A | <input type="text" value="325"/> | psi |
| Comp_on | <input type="text" value="50"/> | psi | High Dis U | <input type="text" value="300"/> | psi |
| Short_Cycle | <input type="text" value="10"/> | sec | Low_Suc_A | <input type="text" value="8"/> | psi |
| Rotation | <input type="text" value="0"/> | min | Low_Suc_T | <input type="text" value="5"/> | min |
| Compressors | <input type="text" value="2"/> | | AMP Xducer | <input type="text" value="10"/> | |
| RLA_Alarm | <input type="text" value="255"/> | | SHeat Lo | <input type="text" value="12"/> | F |
| RLA_Time | <input type="text" value="0"/> | sec | SHeat Hi | <input type="text" value="50"/> | F |
| | | | SHeat Timer | <input type="text" value="0"/> | min |

C1 Config

Compressor rotation is shut off by setting the Rotation to zero. The Compressors must be set to two for the communications to be passed on to C2.

| | | | | | | | | |
|---------------|--|---------|---------------------------------|----------------------------------|--------|----------------------------------|----------------------------------|-----|
| Mode | <input type="text" value="Balanced Head F"/> | LLS OFF | <input type="text" value="20"/> | % | LLS ON | <input type="text" value="30"/> | % | |
| | <input type="text" value="0"/> | Span L | <input type="text" value="30"/> | % | Span U | <input type="text" value="100"/> | % | |
| System Drop | <input type="text" value="70"/> | psi | ST 1 Off | <input type="text" value="50"/> | % | ST 1 On | <input type="text" value="95"/> | % |
| Gas Type | <input type="text" value="R-22"/> | | ST 2 Off | <input type="text" value="59"/> | % | ST 2 On | <input type="text" value="95"/> | % |
| Control Point | <input type="text" value="200"/> | psi | Low Suc U | <input type="text" value="55"/> | psi | Low Suc D | <input type="text" value="60"/> | psi |
| Cond Fan Diff | <input type="text" value="10"/> | psi | Dis Temp U | <input type="text" value="180"/> | F | Dis H Temp | <input type="text" value="200"/> | F |
| RLA_Limit | <input type="text" value="250"/> | amp | | | | | | |
| PID Term | <input type="text" value="0"/> | | | | | | | |

C1 Config

ST 1 is output 7 and is used to control the staging for C2.

| | | | | | |
|----------|--------------------------------|-----|------------------|--------------------------------|-----|
| VIDT | <input type="text" value="0"/> | min | Defrost_off | <input type="text" value="0"/> | psi |
| Suc Diff | <input type="text" value="0"/> | psi | Temp Termination | <input type="text" value="0"/> | F |
| DIT | <input type="text" value="0"/> | min | DTT | <input type="text" value="0"/> | min |
| Max Def | <input type="text" value="0"/> | min | Coil_Dry | <input type="text" value="0"/> | sec |

C1 Config

| | | | | | |
|--------------|----------------------------------|-----|---------------|--|-----|
| Proportional | <input type="text" value="20"/> | | Update | <input type="text" value="50"/> | sec |
| Integral | <input type="text" value="7"/> | | Min Output | <input type="text" value="20"/> | % |
| Derivative | <input type="text" value="0"/> | | Man Output | <input type="text" value="5"/> | % |
| SP | <input type="text" value="200"/> | | Output Offset | <input type="text" value="50"/> | |
| COMP SH H | <input type="text" value="5"/> | F | EVAP SP | <input type="text" value="0"/> | F |
| COMP SH L | <input type="text" value="1"/> | F | EV HI LIMIT | <input type="text" value="0"/> | F |
| EV_UPATE | <input type="text" value="10"/> | min | EV LO LIMIT | <input type="text" value="0"/> | F |
| SH SAFETY | <input type="text" value="0"/> | F | Suc SP | <input type="text" value="60"/> | psi |
| Suc Span | <input type="text" value="20"/> | psi | PID Mode | <input type="text" value="Comp Freq"/> | |

C1 Config

Suc SP is the highest suction pressure that would be needed and would correspond to 0% output from the panel. Suc span would be the total span for 100% output from the panel. With a Suc SP of 60 psi and a Suc span of 20, a 100% signal would give a floating suction SP of 40 psi.

C2 Configuration using Xbase CR-110 inf

Profile Pressure Transducer
 0 - 100 PSI
 0 - 500 PSI
 0 - 750 PSI

Filter 0-10

Network Unit Ma Signal
 4-20 ma
 0-20 ma

Input Mode

Tandem
 Parallel
 LLS Reverse
 UL1 Reverse
 UL2 Reverse

C2 Config

Comp_off psi DPA psi
 Comp_on psi HHPU psi
 Short_Cycle sec Low_Suc_A psi
 Rotation min Low_Suc_T min
 Compressors LSH Inst F
 Unloaders SHeat Lo F
 Low_Ambient F SHeat Hi F
 SHeat Timer min

C2 Config

Mode Liquid Line % Liquid Line %
 Unloader 1 % Unloader 1 %
 System Drop psi Unloader 2 % Unloader 2 %
 Gas Type Unloader 3 % Unloader 3 %
 Control Point psi Low SP 1 psi Low SP 1 psi
 Cond Fan Diff psi Low SP 2 psi Low SP 2 psi
 OSA Diff F
 PID Term

C2 Config

| | | | | | |
|----------|--------------------------------|-----|------------------|--------------------------------|-----|
| VIDT | <input type="text" value="0"/> | min | Defrost_off | <input type="text" value="0"/> | psi |
| Suc Diff | <input type="text" value="0"/> | psi | Temp Termination | <input type="text" value="0"/> | F |
| DIT | <input type="text" value="0"/> | min | DTT | <input type="text" value="0"/> | min |
| Max Def | <input type="text" value="0"/> | min | Coil_Dry | <input type="text" value="0"/> | sec |

C2 Config

| | | | | | |
|--------------|----------------------------------|-----|-------------|-----------------------------------|-----|
| Proportional | <input type="text" value="5"/> | | Update | <input type="text" value="2"/> | sec |
| Integral | <input type="text" value="7"/> | | Min Output | <input type="text" value="20"/> | % |
| Derivative | <input type="text" value="50"/> | | Man Output | <input type="text" value="5"/> | % |
| SP | <input type="text" value="200"/> | | Dead Band | <input type="text" value="0"/> | |
| COMP SH H | <input type="text" value="5"/> | F | Evap SH SP | <input type="text" value="0"/> | F |
| COMP SH L | <input type="text" value="1"/> | F | KI_div | <input type="text" value="0"/> | |
| EV_UPDATE | <input type="text" value="10"/> | min | EV HI LIMIT | <input type="text" value="0"/> | F |
| SH SAFETY | <input type="text" value="0"/> | F | EV LO LIMIT | <input type="text" value="0"/> | F |
| amps | <input type="text" value="1"/> | | PID Mode | <input type="text" value="None"/> | |

C2 Config